

ECOVALDES Branch Choppers

Dipl. Eng. **Ioan PAVEL**¹, PhD Eng. **Gabriela MATACHE**^{1*}, Dipl. Eng. **Alina Iolanda POPESCU**¹,
Tech. **Kati PAVEL**¹, Dipl. Eng. **Ioan MUNTEANU**²

¹ Hydraulics and Pneumatics Research Institute INOE 2000-IHP

² S.C. MNA PROD COM S.R.L.

* fluidas@fluidas.ro

Abstract: *The article presents aspects related to the collection of biomass resulting from the annual cutting in orchards, notions of sizing of choppers and shredders, and some of the achievements resulting from the development of the ECOVALDES project in the segment of branch choppers.*

Keywords: *Biomass, secondary agricultural production, choppers, branch segmentation*

1. Introduction

Wood is the most widely used solid biofuel. The raw material can have the following shapes: logs, stumps, stems, leaves and needles from the forest, bark, sawdust, firewood and wood chips from the wood industry and wood recovered from construction. They can be used chopped when is possible directly as a fuel, or they can be processed into forms that are easier to transport, store and burn, such as: pellets, briquettes and wood dust.

In most cases of energy conversion of biomass, the potential chemical energy from biomass is converted - directly or after some preparatory biological and / or chemical processes - into heat obtained by combustion. We can say that the main form of energy conversion of biomass is its "generic combustion" and the main primary form of usable energy obtained in this way is heat.

The first operation for the use as an energy source of branches resulting from periodic cuttings in orchards and vineyards is their segmentation (chopping) [1].

One of the objectives of capitalizing on biomass is fragmentation (chopping) with the help of special equipment, in order to be used in combustion equipment for the production of thermal energy for domestic or industrial use.

The need to provide heat in the cold season but also for food preparation has been and remains a very important factor in people's lives. Also, the accessibility of the population to the fuels necessary to ensure the current energy, is becoming more and more important both from a logistical and financial point of view. That is why a first conclusion is that wood biomass in its various forms, which is a cheap source of heating and is found in abundance, can provide the energy needed for a part of the population.

The first operation of using as a source of energy the branches resulting from periodic pruning in orchards and vineyards is their segmentation (chopping).

The biomass chopper also has the role of crushing the forest residues resulting from the annual cuttings, obtaining a coarsely segmented wood mass, which will be used either for direct burning in stoves or for crushing to specific granulation for briquetting or pelletizing.

The chopping operation contributes both to the easier handling of biomass and to the creation of a compact finished product for final consumers. In order for the chopping of the branches to be carried out with optimal energy consumption in the specialized literature, there are studies and researches aimed at improving the chopping and shredding equipment, both in terms of design and in terms of fulfilment the requirements of processing of the shredded material after this stage.

The cuttings in the orchards are made in the non-vegetative period and as a result the average humidity of the cut branches is 30-35%. If we take into account a humidity of 35% of a ton of cuttings, by drying up to an average humidity of 15%, it results in 765 kg of biomass usable for the production of thermal energy. It results that a ton of cuttings has an average energy potential of 11.856 MJ or 3.3 MWhth. From a hectare of intensive orchard annually, on average, about 3000 kg of biomass is cut which has an energy potential of 35.628 GJ/ha·year.

The biomass from the cuttings is transported to the row head where it is chopped with a specialized machine at 10 ... 50 mm and stored in containers with perforated walls for a good air circulation. On average, the bulk density of the wet cut is 250 kg/m³, which leads to a need of about 12 containers per hectare of orchard. By natural drying or forced ventilation, the biomass reaches an average humidity of 15% and a bulk density of about 200 kg / m³.

From the published data, for Europe, results an average cost of gathering, chopping and transport for a ton of cuts of about 40 € /t. Taking into account a profit of 20% and VAT it results that a ton of biomass usable for thermal energy production can be sold for about 80 € /t. The specific price for the primary energy of biomass is in the case studied of 5.2 € /GJ or 18.6 € /MWhth, values much lower than those for diesel of 33.22 € /GJ or for LPG of 21.52 € /GJ [2].

2. General data on the sizing of shredding and chopping equipment

1. For shredders, the useful characteristics of shredding processes [3] should include the torque M_o (1), the grinding time t , the power of the shredder P , the energy consumed for shredding E (2):

$$M_o = r \cdot F = \frac{P}{\omega} \quad (1)$$

where: r - force radius vector (m);

F - active force (N);

ω - angular velocity of cutting parts (rad s⁻¹)

and:

$$E = P \cdot t = F \cdot r \cdot \omega \cdot t \quad (2)$$

2. In the case of choppers, the cutting force varies to a very large extent depending on the structure of the wood, its length and diameter, knots, species, distribution of fibers, etc.

For sizing the chopping equipment, start with the force required for the cutting process:

$$F = K \cdot p \cdot L \cdot d \quad (3)$$

where: k - a coefficient that takes into account the angle of the knife and the state of sharpening, the species and the humidity of the wood; indicative values between 0.003 and 0.009;

p - specific resistance to cutting.

The resistance to compression parallel to the fibers has values between 30 - 90 N/mm², depending on the essence of the wood.

L, d - length and diameter of the wood to be cut.

For the calculation, values will be chosen slightly above average.

$$F = 0.009 \cdot 70 \cdot 40 \cdot 40$$

$$F = 1008 \text{ N} = 100,8 \text{ kgf}$$

It is taken into account:

$$F_{max} = 100 \text{ kgf} \quad [4]$$

Recent studies indicate that repair and maintenance represent about 15% of the total chopper cost [5]. As expected, maintenance cost increases over time, and the rate of increase follows approximately the same curve shape as found for most agricultural machines [6]. Normally, maintenance cost is expressed as total accumulated repair (TAR) and is referred to purchase price. In the specific case of choppers, the % ratio between TAR and purchase price has been described by [5] through the following equation (Eq. 4):

$$\text{TAR/price} = 3.408 \cdot 10^{-4} \cdot \text{Hours}^{0.83} + 8.635 \cdot 10^{-5} \cdot \text{Hours} \cdot \text{Used} \quad (4)$$

Where: Hours= total hours worked at the time of the estimate

Used = indicator variable: 0 if the chopper was bought new, 1 if the chopper was bought second-hand.

Knife cost represents the largest proportion of chopper maintenance cost.

3. Choosing the type of chopping equipment

Vegetable waste choppers can be classified according to the way the material is chopped or according to the type of machine feed. The choice will be made taking into account the material to be crushed (the thickness and hardness of the branches) and the existence or non-existence of a source of electricity. Depending on the size and position of the household in relation to the biomass, it is decided the most efficient motorization that the chopper must have. Usually, for large households, the most efficient are gasoline heat engines, because they have the ability to easily chop thicker branches and enjoy increased maneuverability, being able to be placed in any corner of the household and even apart from her. Even if the noise produced by them is more intense than that of electric motors, this type of chopper proves its efficiency in large gardens. On the other hand, the electric motor is suitable for small households because it requires a permanent power supply. Thus, if the garden benefits from the connection to a power source, then electric choppers are suitable to meet the needs of the user. In fact, there is another type of power supply suitable for branch choppers: the connection to the direct socket of the tractor. In conclusion, the garden needs a branch chopper, whether it is small or large. This machine helps to save time, money and vegetable material that we reuse in the household. You can opt for a plant that has as fuel the residues obtained by chopping the branches, or you can keep the material obtained to use it as fertilizer for the soil.

4. The choppers made in the project ECOVALDES

Under the ECOVALDES project, prototypes were made for shredding, chopping, transporting, drying, pelletizing, breaking and burning equipment. The combination of these equipment pieces can result in 26 technological lines for processing raw materials in the form of wooden logs, branches or sawdust.

In the range of branch choppers, four prototypes of equipment were made, of which, two heat-powered choppers and one electric-powered chopper and a shredder. The following are the following equipment:

4.1. Chopper driven with thermal engine of 6.5 CP



Fig. 1. Chopper driven with thermal engine of 6.5 CP

Technical specifications:

Type of drive: gasoline engine

Engine power: 6.5 CP

Average consumption: 1.5-2.3 L

Fuel type: Petrol 95

Tank capacity: 2.5 L

Number of knives: 6 pcs. (3 on each axis)

Outer dimension of the funnel: 540 x 390 mm

Ømax. green softwood: 50

Ømax. green hardwood: 45 mm

Ømax. dry hardwood: 40 mm

Length of chopped pieces of branches: 50-120 mm (not adjustable)

Productivity: max. 4 m³ / hour

4.2. Chopper driven with thermal engine of 13 CP

Fig. 2. Chopper driven with thermal engine of 13 CP

Technical specifications:

Type of drive: gasoline engine
 Engine power: 13 CP
 Average consumption: 423 g/CP*h
 Fuel type: Natural 95
 Tank capacity: 6.5 L
 Number of knives: 6 pcs. (3 on each axis)
 Outer dimension of the funnel: 540 x 390 mm
 Ømax. green softwood: 60
 Ømax. green hardwood: 45 mm
 Ømax. dry hardwood: 40 mm
 Length of chopped pieces of branches: 50-120 mm (not adjustable)
 Productivity: max. 6 m³ / hour

4.3. Chopper driven with electric engine of 2.2 kW

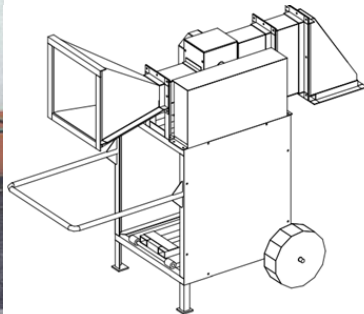
Fig. 3. Chopper driven with electric engine of 2.2 kW

Technical specifications:

Product type: Chopper
 Type of engine: Single-phase asynchronous electric engine type
 Supply voltage: 230V-240V
 Engine power 2.2 kW
 Maximum recommended cutting diameter: 30 mm
 Dimensions of the chopped material (length, thickness): 60 mm; 30 mm
 Type of chopping machine: Knife with 4 double-edged blades
 Working capacity of the machine: 250 kg / h

4.4. Shredder driven with electric engine of 4 kW

Fig. 4. Shredder driven with electric engine of 4 kW

Technical specifications:

Product type: Shredder
 Type of engine: Single-phase asynchronous electric engine
 Supply voltage: 230V-240V
 Engine power 4 kW
 Recommended cutting diameter: 70 mm
 Dimensions of the shredded material (length, thickness): 10 mm; 10 mm
 Type of shredding machine: Knife with 2 cutting blades and counter-knife
 Working capacity of the machine: 250 kg / h

4.5 Patent

Also in the framework of the project, a patent application was filed for a "Branch chopper with pulling knife" presented below:

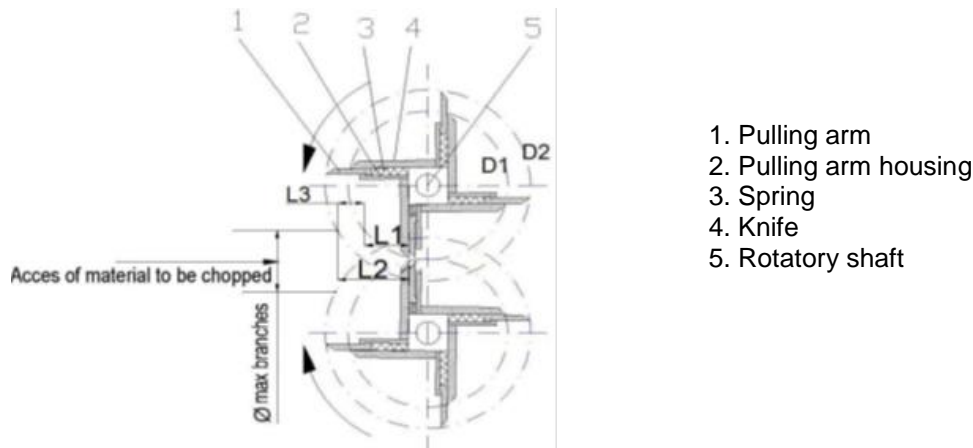

Fig. 5. Chopping assembly

The chopping assembly according to fig. 5 consists of two axles, one drive axle, actuated by the belt wheel and one drive axle led by a gearing with gears with transmission ratio 1. The shaft (5) is bearing at the ends and the central part is square in shape. The cutting knives (4) are screwed to each side of the square. On each cutting knife is mounted with screws a housing (2) in which the pulling arm (1) is seized which slides in the housing against a spring (3). When the chopping material is touched, the pulling arm (1) takes it and pushes it forward until the two cutting knives (4) positioned in the mirror cut the chopping material, with length L2, larger by L3 compared to the version without pulling arm L1 [7].

5. Conclusions

In general, in addition to energy recovery from waste, the aim is:

- Replacement of fossil fuels such as fuel oil, fuel gas or coke (conservation / protection of resources);
- Reducing the impact of CO₂ emissions on the climate (climate protection);
- Reducing the dependence of global energy markets connected with reducing costs;
- Increasing the degree of flexibility of waste management by reducing the amount of residual waste.

Arguments in support of biomass use:

- Diversify energy supply sources
- Replaces conventional fuels with high CO₂ emissions
- Contributes to waste recycling
- Protects and creates jobs in rural areas.

The advantages of chopped biomass obtained with the chopper with pulling knife are the following:

- Larger firewood segments are obtained that behave better when burning in stoves
- Can be handled more easily
- They can be stored easier and with smaller volumes
- Wood material from secondary agricultural production are used
- It creates a source of ecological energy from renewable sources.

Acknowledgments

This paper has been developed in INOE 2000-IHP, as part of a project co-financed by the European Union through the European Regional Development Fund, under Competitiveness Operational Programme 2014-2020, Priority Axis 1: Research, technological development and

innovation (RD&I) to support economic competitiveness and business development, Action 1.2.3 – Partnerships for knowledge transfer, project title: Eco-innovative technologies for recovery of biomass wastes, project acronym: ECOVALDES, SMIS code: 105693-594, Financial agreement no. 129/23.09.2016.

References

- [1] Pavel, Ioan, Gabriela Matache, Alexandru - Polifron Chiriță, Alina - Iolanda Popescu, and Cristian Diaconu. “Biomass Processing from Agricultural Residual Production and Maintenance Operations when Cutting Trees and Vines.” *Hidraulica Magazine*, no. 4 (December 2020): 93-97.
- [2] Murad, Erol, M. Seiculescu, C. Sima, and G. Haraga. “The use of the energetic potential of the vine ropes / Utilizarea potențialului energetic al corzilor de viță.” Paper presented at Scientific Communications Conference, INCVV Valea Călugărească, Romania, June 10, 2010.
- [3] Spinelli, R. and E. Marchi. “Trends and Perspectives in the Design of Mobile Wood Chippers.” *Croatian Journal of Forest Engineering* 42, no.1 (2021): 25-38.
- [4] Șalaru, Gheorghe, Aurelia Bahnaru, Alexandru Jolondcovschi, Radu Osipov, and Alexandru Golic. “Biodegradable wastes management (Material and energy recovery)” / “Managementul deșeurilor biodegradabile (Valorificare materială și energetică)”. Chisinau, 2013. Accessed November 18, 2021. <https://e-circular.org/wp-content/uploads/2020/06/Managementul-deșeurilor-biodegradabile.pdf>.
- [5] Spinelli, R., and A.C. de Arruda Moura. “Productivity and Utilization Benchmarks for Chain Flail Delimber-Debarkers-Choppers Used in Fast-Growing Plantations”. *Croatian Journal of Forest Engineering* 40, no.1 (2019): 65–80.
- [6] Abdelmotaleb, I.” Repair and maintenance cost analysis of tractors and combines”. PhD Thesis. Iowa State University, Ames, IA, USA, 1989.
- [7] Pavel, Ioan, Gabriela Matache, and Gheorghe Șovăială. “Branch chopper with pulling knife” / “Tocător cu cuțit trăgător.” Patent application no. A / 00408 on 15.07.2020.